

The mesytec MPR-Series provides a set of state of the art multichannel preamplifier modules specially designed for single or double sided multistrip silicon detectors. The MPR series can be used as stand alone modules and can also easily be combined with the mesytec STM-16 shaping-/timing filter/ discriminator module.

### Features:

- 16 / 32 / 64 channel compact module
- Sensitivity switch, factor 5
- ESD input protection
- Differential output 100  $\Omega$  or
- MPR16L with Lemo output connectors.
- Pulser input
- Bias voltage up to  $\pm 400V$
- PCB module available for vacuum use



### Schematics:

(for MPR-16)

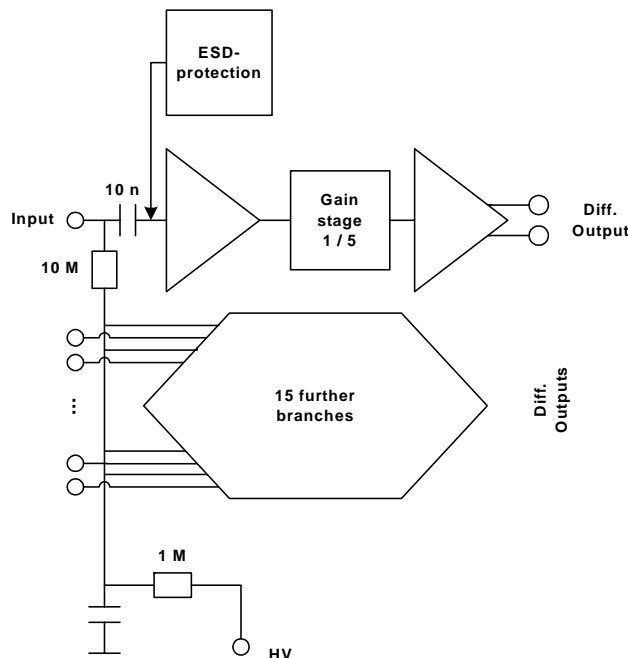

## Technical Data

### Energy ranges

The MPR series provides a switch to amplify the output signal by a factor of 5. This helps to provide large output signals even at low charge depositions and thus provides good noise immunity.

With STM16+ the energy range (for gainjumper G2) is 2x specified energy range for lowest gain and specified energy range / 10 for highest gain. Another amplification factor of 5 can be added by preamp gain switch. For the 25MeV type this means: maximum 50MeV full range to 500keV full range.

### Input stage

- Input connector(s): subD 25 female connector (for a 16 channel unit)
- Pin assignment:

Function	connector	Function	connector
Sig-gnd	1,2,7,12,13,14,15,25	Cha 9	19
Cha 1	11	Cha 10	6
Cha 2	23	Cha 11	18
Cha 3	10	Cha 12	5
Cha 4	22	Cha 13	17
Cha 5	9	Cha 14	4
Cha 6	21	Cha 15	16
Cha 7	8	Cha 16	3
Cha 8	20	guardring	24

- Positive and negative charge can be amplified equally.
- The guardring output (24) is connected via R-C- R filter (100k $\Omega$ , 10nF, 100k $\Omega$ ) to the common detector bias input.

### Output stage:

- Differential output for twisted pair 34 pin male header connector.
- Output amplitude:  $\pm 1.2$  V for specified energy range (headroom  $\pm 4$ V)
- Pin assignment of output connector:  
pin 1,2 channel 1, pin 3,4 channel 2.....  
pin 33, 34 output ground

### Rise and decay time:

Standard decay times are 10 $\mu$ s, 20 $\mu$ s, 50 $\mu$ s 100 $\mu$ s.  
Risetime is 12ns for 0pF input capacity.

### Noise

For the MPR-16 series, power modes can be selected by a jumper on the PCB.

High Power mode reduces noise, while low Power mode may be useful for in vacuum use.

power mode	shaping time	MPR16-25 MPR16-100
	$\sigma$ / FWHM [us]	noise [keV] FWHM
LP	0.4 / 1	(5 + 0.06/pF)
	1 / 2.5	(4 + 0.04/pF)
HP	0.4 / 1	(5 + 0.04/pF)
	1 / 2.5	(4 + 0.027/pF)

### Pulsar input

The pulser is internally distributed to individual charge termination capacities. Tolerances  $\pm 10\%$ .

MPR16-25	MPR16-100	MPR16-1500
0.78pF (17 MeV/V)	1.13pF (25 MeV/V)	10.2pF (230 MeV/V)

### Detector bias input

- Lemo connector
- Maximum voltage  $\pm 400$  V
- When connected detector side must be on ground level: terminate bias input with 50 $\Omega$  Lemo terminator.

### Ground connections

- Ground screws on front and rear side
- There are two different ground connections: input and output ground.
- Input ground is connected to the vacuum vessel if the setup is not isolated (ie. isolated flange).
- In critical environment the output ground can be connected to the NIM electronics.

### Power connector:

SubD9 connector:

- 1, 2 = gnd
- 3 = +6V
- 4 = +12V
- 5 = -6V

**Pinout of on board power connector for PCB version:**

- gnd: 1,3,10,11,12
- +12V: 7
- +6V: 5
- -6V: 9
- LED+: 13 ("power ok" LED)
- LED-: 14

**Power consumption for 16 channels:**

Parameter	MPR16-25 MPR16-100	MPR16-500 MPR16-1500
	<b>current [mA]</b>	
LP/HP +6V	50	50
LP/HP -6V	50	50
LP +12V	40	-
HP +12V	80	40
total power LP-mode	1.1W	-
total power HP-mode	1.6W	1.1W

LP= low power mode, HP = high power mode

**Cooling**

Due to the low power consumption cooling is not necessary.

For **in vacuum use**, select low power mode if possible. The power of a single PCB can be dissipated without problems. If several PCBs are densely packed, heat conducting metal shields should be placed in between the PCBs.

Avoid to warm up silicon detectors by the dissipated power.

**Dimensions:**

- Length: 173 mm (without connectors)
- Width: 105 mm
- Height: 46 mm (MPR-16),  
67 mm (MPR-32),  
92 mm (MPR-64)